

**UNITED STATES DISTRICT COURT
FOR THE DISTRICT OF NORTH DAKOTA
WESTERN DIVISION**

**FIREARMS REGULATORY
ACCOUNTABILITY COALITION, INC.,**

**STATES OF WEST VIRGINIA, NORTH
DAKOTA, ALABAMA, ALASKA,
ARKANSAS, FLORIDA, GEORGIA,
IDAHO, INDIANA, IOWA, KANSAS,
KENTUCKY, LOUISIANA, MISSISSIPPI,
MISSOURI, MONTANA, NEBRASKA,
NEW HAMPSHIRE, OKLAHOMA,
SOUTH CAROLINA, SOUTH DAKOTA,
TENNESSEE, UTAH, VIRGINIA, and
WYOMING,**

NST GLOBAL, LLC d/b/a SB TACTICAL,

B&T USA, LLC,

RICHARD CICERO,

Plaintiffs,

v.

**MERRICK B. GARLAND, IN HIS
OFFICIAL CAPACITY, as Attorney
General of the United States,**

**THE BUREAU OF ALCOHOL,
TOBACCO, FIREARMS AND
EXPLOSIVES,**

**STEVEN DETTELBACH, IN HIS
OFFICIAL CAPACITY, as Director of the
Bureau of Alcohol, Tobacco, Firearms and
Explosives,**

Defendants.

Civil Action No. _____

**COMPLAINT FOR
DECLARATORY AND
INJUNCTIVE RELIEF**

Plaintiffs, by and through undersigned counsel, file this Complaint pursuant to the Administrative Procedure Act, 5 U.S.C. §§ 701–06, alleging as follows.

INTRODUCTION

1. For more than a decade, the Bureau of Alcohol, Tobacco, Firearms and Explosives (“ATF”) authorized the public to use pistol stabilizing braces, a popular firearms accessory, without federal regulation. During that time, ATF repeatedly issued letter rulings assuring manufacturers and the public that attaching a stabilizing brace would not alter the statutory or regulatory classification of a pistol or other firearm.

2. As a result, millions of Americans have for years lawfully purchased stabilizing braces and pistols equipped with stabilizing braces from authorized, legitimate manufacturers with ATF’s full knowledge and express approval.

3. Then everything changed. Frustrated with congressional inaction, the President of the United States ordered ATF to abandon a decade of practice under an established statutory framework and “to treat pistols modified with stabilizing braces” as “subject to the National Firearms Act.” President’s Remarks on Gun Violence Prevention Efforts, 2021 Daily Comp. Pres. Doc. 298, at 3 (Apr. 8, 2021). This “change,” the President said, would require an owner of a pistol equipped with a stabilizing brace to “pay a \$200 fee and submit their name and other identifying information to the Justice Department” or face criminal penalties. *Ibid.* The President’s express aim was to act “without having to go through the Congress.” *Id.* at 2.

4. On January 31, 2023, ATF responded with the Rule at issue in this case. Although the Rule purports to provide “factoring criteria” to “clarify” how ATF will determine whether any particular weapons configuration is subject to heightened regulation, Factoring Criteria for Firearms with Attached “Stabilizing Braces,” 88 Fed. Reg. 6,478 (Jan. 31, 2023) (“Rule”), attached as Ex. A, the Rule in effect vests ATF with unbounded discretion. And ATF has made clear exactly how it intends to exercise that discretion, estimating that, under the Rule, 99% of pistols equipped with stabilizing braces will now be deemed subject to National Firearms Act (“NFA”) controls,

Final Regulatory Impact Analysis and Final Regulatory Flexibility Analysis, at 21 (Jan. 2023) (“Regulatory Analysis”), attached as Ex. B. According to ATF, the “clarification” will result in the destruction or forfeiture of over 750,000 firearms and will cost the private sector somewhere between two and five billion dollars. *Id.* at 56–57, 62–67.

5. The Rule thus represents an abrupt reversal of ATF’s longstanding position that these items are not subject to NFA controls or heightened Gun Control Act, or “GCA” regulations. The reversal will require millions of Americans to choose between the loss of their lawful (and lawfully acquired) firearms, the loss of their privacy, and the risk of criminal penalties.

6. Incredibly, ATF claims that this result was required all along. But a plain reading of the statutory language, paired with an understanding of Congress’s purposes in enacting it, reveals that a pistol or other firearm equipped with a stabilizing brace is excluded from the applicable definitions set forth in the NFA (as well as the GCA). Congress enacted the NFA to regulate “sawed-off guns” and other dangerous weapons favored by criminal “gangster[s]” for concealability and indiscriminate accuracy, and specifically left “without any restriction” “pistols and revolvers and sporting arms.” H.R. Rep. No. 73-1780 (1934). The Rule, by contrast, regulates pistols and other firearms based on accessories designed as orthotics that make them *less* concealable, *more* accurate, and *less* dangerous, thereby undermining public safety. That approach is unambiguously foreclosed by the text, history, and purpose of the NFA and GCA.

7. At a minimum, the statutes are grievously ambiguous. *See United States v. Thompson/Ctr. Arms Co.*, 504 U.S. 505, 517–18 (1992) (plurality) (applying rule of lenity to prevent NFA regulation of pistol sold with a shoulder stock and a 21-inch barrel); *id.* at 519 (Scalia, J., concurring); *Cargill v. Garland*, 57 F.4th 447, 469–71 (5th Cir. 2023) (applying rule of lenity to prevent NFA and GCA regulation of bump stocks). If the agency charged with administering

the NFA and GCA believed *for years* that pistols equipped with stabilizing braces are not subject to heightened regulation and now holds the opposite, the statutes are at the very least ambiguous as applied to such weapons. Lenity thus demands that the Rule be set aside.

8. Finally, the Rule and its accompanying Adjudications are, in any event, arbitrary and capricious on multiple counts. The “standard” for determining whether a brace is designed and intended for shouldering is incoherent and unworkable, and ATF’s Adjudications fail to provide any explanation or justification for those decisions.

9. This Court should not let ATF’s unlawful actions stand and must set aside the Rule and Adjudications.

PARTIES

10. Plaintiff Firearms Regulatory Accountability Coalition, Inc. (“FRAC”) is a non-profit association working to improve business conditions for the firearms industry by ensuring the industry receives fair and consistent treatment from firearms regulatory agencies. FRAC serves as the premiere national trade association representing U.S. firearms manufacturers, retailers, importers, and innovators on regulatory and legislative issues impacting the industry in the United States.

11. As part of its advocacy, FRAC regularly files comments with firearms regulatory agencies and litigates firearms regulatory issues. *See, e.g.*, Comments of FRAC, et al., Docket No. ATF 2021R–08, AG Order No. 5070–2021 (filed Sept. 8, 2021) (“FRAC Comments”), attached as Ex. E; Amicus Br. of FRAC, et al., *Cargill v. Garland*, No. 20-51016 (5th Cir. Aug. 1, 2022)¹; Complaint, *Firearms Regulatory Accountability Coalition v. Garland*, Civil Action No. 23-cv-

¹ <https://www.fracaction.org/post/frac-files-joint-amicus-brief-in-cargill-v-garland-asks-court-to-rein-in-atf>.

0003 (D.N.D. Jan. 4, 2023).²

12. FRAC is headquartered and maintains its principal place of business at 2021 E. Main Avenue, Suite I, Bismarck, ND 58501.

13. Plaintiff NST Global, LLC d/b/a SB Tactical (“SB Tactical”) is a limited liability company that specializes in manufacturing stabilizing braces. SB Tactical’s founder Alex Bosco—a Marine Corps and Army veteran—invented the original pistol stabilizing brace with the goal of helping disabled combat veterans safely and accurately fire weapons.

14. SB Tactical is a member of FRAC.

15. Plaintiff Richard Cicero is a retired police firearms instructor and a wounded warrior. Mr. Cicero lost an arm and a leg while serving his country in Afghanistan. As a result, he has to use stabilizing braces to safely fire many weapons. He has trained hundreds of physically challenged students, many of them also wounded combat veterans, to safely fire pistols with the help of stabilizing braces.

16. Plaintiff B&T USA, LLC (“B&T”) is a federally licensed firearms importer and manufacturer. Approximately three-quarters of B&T’s sales are products designed to be equipped with stabilizing braces.

17. B&T is a member of FRAC.

18. Plaintiff State of West Virginia is a sovereign state of the United States of America. West Virginia sues to vindicate its sovereign, quasi-sovereign, and proprietary interests, including its interests in protecting its citizens, businesses, employees, public fisc, and tax revenue. West Virginia brings this suit through its Attorney General, Patrick Morrissey. He is the chief legal officer of the State of West Virginia and has the authority to represent the State in federal court.

² https://www.fracaction.org/_files/ugd/054dfe_2d3e409cbd364765834d72bbe778c482.pdf.

19. Plaintiff State of North Dakota is a sovereign state of the United States of America. North Dakota sues to vindicate its sovereign, quasi-sovereign, and proprietary interests, including its interests in protecting its citizens, businesses, employees, public fisc, and tax revenue. North Dakota brings this suit through its Attorney General, Drew H. Wrigley. He is the chief legal officer of the State of North Dakota and has the authority to represent the State in federal court.

20. Plaintiff State of Alabama is a sovereign state of the United States of America. Alabama sues to vindicate its sovereign, quasi-sovereign, and proprietary interests, including its interests in protecting its citizens, businesses, employees, and tax revenue. Alabama brings this suit through its Attorney General, Steve Marshall. He is the chief legal officer of the State of Alabama and has the authority to represent the State in federal court.

21. Plaintiff State of Alaska is a sovereign state of the United States of America. Alaska sues to vindicate its sovereign, quasi-sovereign, and proprietary interests, including its interests in protecting its citizens, businesses, employees, and natural resources. Alaskans encounter megafauna, including moose and bears, in their daily lives. While many encounters are benign, moose and bears are unpredictable; an Alaskan facing a moose or bear charge requires quick reflexes and often a dependable, accurate firearm to survive unscathed. Alaska brings this suit through its Attorney General, Treg Taylor. He is the chief legal officer of the State of Alaska and has the authority to represent the State in federal court.

22. Plaintiff State of Arkansas is a sovereign state of the United States of America. Arkansas sues to vindicate its sovereign, quasi-sovereign, and proprietary interests, including its interests in protecting its citizens, businesses, employees, and tax revenue. Arkansas brings this suit through its Attorney General, Tim Griffin. He is the chief legal officer of the State of Arkansas and has the authority to represent the State in federal court. *See* Ark. Code Ann. § 25-16-703(a).

23. Plaintiff State of Florida is a sovereign state of the United States of America. Florida sues to vindicate its sovereign, quasi-sovereign, and proprietary interests, including its interests in protecting its citizens, businesses, employees, and tax revenue. Florida brings this suit through its Attorney General, Ashley Moody. She is the chief legal officer of the State of Florida and has the authority to represent the State in federal court.

24. Plaintiff State of Georgia is a sovereign state of the United States of America. Georgia sues to vindicate its sovereign, quasi-sovereign, and proprietary interests, including its interests in protecting its citizens, businesses, employees, and tax revenue. Georgia brings this suit through its Attorney General, Christopher Carr. He is the chief legal officer of the State of Georgia and has the authority to represent the State in federal court.

25. Plaintiff State of Idaho is a sovereign state of the United States of America. Idaho sues to vindicate its sovereign, quasi-sovereign, and proprietary interests, including its interests in protecting its citizens, businesses, employees, public fisc, and tax revenue. Idaho brings this suit through its Attorney General, Raúl Labrador. He is the chief legal officer of the State of Idaho and has the authority to represent the State in federal court.

26. Plaintiff State of Indiana is a sovereign state of the United States of America. Indiana sues to vindicate its sovereign, quasi-sovereign, and proprietary interests, including its interests in protecting its citizens, businesses, employees, and tax revenue. Indiana brings this suit through its Attorney General, Todd Rokita. He is the chief legal officer of the State of Indiana and has the authority to represent the State in federal court.

27. Plaintiff State of Iowa is a sovereign state of the United States of America. Iowa sues to vindicate its sovereign, quasi-sovereign, and proprietary interests, including its interests in protecting its citizens, businesses, employees, and tax revenue. Iowa brings this suit through its

Attorney General, Brenna Bird. She is the chief legal officer of the State of Iowa and has the authority to represent the State in federal court.

28. Plaintiff State of Kansas is a sovereign state of the United States of America. Kansas sues to vindicate its sovereign, quasi-sovereign, and proprietary interests, including its interests in protecting its citizens, businesses, employees, and tax revenue. Kansas brings this suit through its attorney general Kris W. Kobach. He is the chief legal officer of the State of Kansas and has the authority to represent the State in federal court.

29. Plaintiff Commonwealth of Kentucky is a sovereign state of the United States of America. Kentucky sues to vindicate its sovereign, quasi-sovereign, and proprietary interests, including its interests in protecting its citizens, businesses, employees, and tax revenue. Kentucky brings this suit through its Attorney General, Daniel Cameron. He is the chief legal officer of the Commonwealth of Kentucky and has the authority to represent the Commonwealth in federal court. Ky. Rev. Stat. § 15.020.

30. Plaintiff State of Louisiana is a sovereign state of the United States of America. Louisiana sues to vindicate its sovereign, quasi-sovereign, and proprietary interests, including its interests in protecting its citizens, businesses, employees, public fisc, and tax revenue. Louisiana brings this suit through its Attorney General, Jeff Landry. He is the chief legal officer of the State of Louisiana and has the authority to represent the State in federal court.

31. Plaintiff State of Mississippi is a sovereign state of the United States of America. Mississippi sues to vindicate its sovereign, quasi-sovereign, and proprietary interests, including its interests in protecting its citizens, businesses, employees, and tax revenue. Mississippi brings this suit through its Attorney General, Lynn Fitch. She is the chief legal officer of the State of Mississippi and has the authority to represent the State in federal court.

32. Plaintiff State of Missouri is a sovereign state of the United States of America. Missouri sues to vindicate its sovereign, quasi-sovereign, and proprietary interests, including its interests in protecting its citizens, businesses, employees, public fisc, and tax revenue. Missouri brings this suit through its Attorney General, Andrew Bailey, the chief law enforcement officer of the state.

33. Plaintiff State of Montana is a sovereign state of the United States of America. Montana sues to vindicate its sovereign, quasi-sovereign, and proprietary interests, including its interests in protecting its citizens, businesses, employees, and tax revenue. Montana brings this suit through its Attorney General, Austin Knudsen. He is the chief legal officer of the State of Montana and has the authority to represent the State in federal court.

34. Plaintiff State of Nebraska is a sovereign state of the United States of America. Nebraska sues to vindicate its sovereign, quasi-sovereign, and proprietary interests, including its interests in protecting its citizens, businesses, employees, and tax revenue. Nebraska brings this suit through its Attorney General, Michael T. Hilgers. He is the chief legal officer of the State of Nebraska and has the authority to represent the State in federal court.

35. Plaintiff State of New Hampshire is a sovereign state of the United States of America. New Hampshire sues to vindicate its sovereign, quasi-sovereign, and proprietary interests, including its interests in protecting its citizens, businesses, employees, and tax revenue. New Hampshire brings this suit through its Attorney General, John M. Formella. He is the chief legal officer of the State of New Hampshire and has the authority to represent the State in federal court.

36. Plaintiff State of Oklahoma is a sovereign state of the United States of America. Oklahoma sues to vindicate its sovereign, quasi-sovereign, and proprietary interests, including its interests in protecting its citizens, businesses, employees, and tax revenue. Oklahoma brings this suit through its Attorney General, Gentner F. Drummond. He is the chief legal officer of the State

of Oklahoma and has the authority to represent the State in federal court. He also represents a multitude of State Law Enforcement Officers or Agents who will be impacted by this Rule.

37. Plaintiff State of South Carolina is a sovereign state of the United States of America. South Carolina sues to vindicate its sovereign, quasi-sovereign, and proprietary interests, including its interests in protecting its citizens, businesses, employees, public fisc, and tax revenue. South Carolina brings this suit through its Attorney General, Alan Wilson. He is the chief legal officer of the State of South Carolina and has the authority to represent the State in federal court.

38. Plaintiff State of South Dakota sues to vindicate its sovereign, quasi-sovereign, and proprietary interests, including its interests in protecting its citizens, businesses, employees, public fisc, and tax revenue. South Dakota brings this suit through its Attorney General, Marty J. Jackley. He is the chief legal officer of the State of South Dakota and has the authority to represent the State in federal court.

39. Plaintiff State of Tennessee is a sovereign state of the United States of America. Tennessee sues to vindicate its sovereign, quasi-sovereign, and proprietary interests, including its interests in protecting its citizens, businesses, employees, and tax revenue. Tennessee brings this suit through its Attorney General, Jonathan Skrmetti. He is the chief legal officer of the State of Tennessee and has the authority to represent the State in federal court.

40. Plaintiff State of Utah is a sovereign state of the United States of America. Utah sues to vindicate its sovereign, quasi-sovereign, and proprietary interests, including its interests in protecting its citizens, businesses, employees, and tax revenue. Utah brings this suit through its Attorney General, Sean D. Reyes. He is the chief legal officer of the State of Utah and has the authority to represent the State in federal court.

41. Plaintiff Commonwealth of Virginia is a sovereign state of the United States of America. Virginia sues to vindicate its sovereign, quasi-sovereign, and proprietary interests, including its interests in protecting its citizens, businesses, employees, and tax revenue. Virginia brings this suit through its Attorney General, Jason Miyares. He is the chief legal officer of the Commonwealth of Virginia and has the duty under Va. Code § 2.2-513 to “represent the interests of the Commonwealth . . . in matters before or controversies with the officers and several departments of the government of the United States.”

42. Plaintiff State of Wyoming is a sovereign state of the United States of America. Wyoming sues to vindicate its sovereign, quasi-sovereign, and proprietary interests, including its interests in protecting its citizens, businesses, employees, and tax revenue. Wyoming brings this suit through its Attorney General, Bridget Hill. She is the chief legal officer of the State of Wyoming and has the authority to represent the State in federal court.

43. Defendant Merrick B. Garland (“the Attorney General”) is the Attorney General of the United States. He leads the Department of Justice (“DOJ”), an executive department of the United States. 28 U.S.C. §§ 501, 503. He is vested with authority to enforce the Gun Control Act, *see* 18 U.S.C. §§ 922, 926, and provisions of the National Firearms Act at issue in this case, 26 U.S.C. § 7801(a)(2).

44. Defendant Bureau of Alcohol, Tobacco, Firearms and Explosives (“ATF”) is a Bureau within DOJ. 28 U.S.C. § 599A(a)(1).

45. Defendant Steven M. Dettelbach (“the Director”) is the Director of ATF. The Attorney General has delegated to the Director authority to enforce the Gun Control Act and the provisions of the National Firearms Act at issue in this case. *See* 28 C.F.R. § 0.130(a)(1), (3); *accord* 28 U.S.C. § 510.

46. This Complaint refers to all Defendants collectively as ATF.

JURISDICTION AND VENUE

47. This Court has jurisdiction under 28 U.S.C. § 1331 because this civil action arises under the laws of the United States and challenges final agency action. 5 U.S.C. §§ 701–06.

48. Plaintiffs cannot seek another adequate remedy in court. *Id.* § 704.

49. Venue is proper in this Court because Defendants are officers and agencies of the United States, no real property is involved in this action, and Plaintiff FRAC and Plaintiff North Dakota reside in this judicial district. 28 U.S.C. § 1391(e)(1).

STANDING

SB TACTICAL’S STANDING

50. SB Tactical is financially injured by ATF’s unlawful Rule and Adjudications. Declaration of Jeff Creamer, ¶¶ 40–45 (“Creamer Decl.”), attached as Ex. G.

51. The Rule effectively renders every firearm equipped with an SB Tactical brace a short-barreled rifle. More than 40 of the 67 Adjudications classifying firearms as short-barreled rifles apply to weapons equipped with an SB Tactical brace. *See id.* ¶ 33.

52. SB Tactical’s sales have plummeted from selling an average of 92,000 braces per month before ATF initiated its unlawful regulatory actions to selling only 19,300 braces in January 2023. *Id.* ¶ 41. The Rule became public in mid-January and became effective January 31.

53. SB Tactical expects its sales to fall even further now that the Rule is effective. *Id.* ¶ 41.

54. Because sales of stabilizing braces comprise 98.82% of SB Tactical’s revenues, this drop in sales has severely disrupted SB Tactical’s business. *Id.* ¶ 42.

55. Indeed, SB Tactical was forced to reduce its workforce by 61% after ATF issued its Notice. *Id.* ¶ 43.

56. With the further drop in sales following the issuance of the Rule, SB Tactical will lay off

six of its 12 remaining employees within the next 60 days in an effort to stay afloat. *Id.* ¶ 44.

57. SB Tactical predicts that—if this trend continues—SB Tactical may go out of business within a matter of months. *Id.* ¶¶ 45, 47.

58. SB Tactical’s reputation has also suffered as a result of many of its products unexpectedly triggering onerous federal firearms regulations and as a result of ATF repeatedly and expressly disparaging SB Tactical in the Preamble to the Rule. *Id.* ¶¶ 35–37, 46.

59. These injuries are directly caused by ATF’s unlawful Rule and Adjudications. *Id.* ¶¶ 38–48.

60. These injuries would be redressed by an order of this Court setting aside the Rule and Adjudications, as firearms owners would then be able to once again attach SB Tactical braces to their firearms without being subject to heightened regulation under the NFA and the GCA. *Id.* ¶ 48.

61. These injuries are ongoing and irreparable.

B&T’S STANDING

62. B&T is financially injured by ATF’s unlawful Rule and Adjudications. Declaration of Irving Luce, ¶¶ 11–17 (“Luce Decl.”), attached as Ex. H.

63. B&T imports and manufactures pistols that are specifically designed to be used with stabilizing braces. *Id.* ¶ 6.

64. Approximately 73% of B&T’s revenues derive from sales of pistols and accessories designed to be affixed with stabilizing braces. *Ibid.*

65. Since ATF published a draft of the Rule on the agency’s website on January 13, 2023, B&T’s sales have plummeted. B&T was selling approximately 200 specialized pistols per week prior to ATF’s announcement of the Rule, but it has thus far been unable to sell any of those pistols after the announcement of the Rule. *Id.* ¶ 15.

66. B&T has already invested time and labor to determine which, if any, of the over 2,000 guns in its inventory are covered by the Rule and Adjudications. *Id.* ¶ 11.

67. B&T expects to expend thousands of dollars in materials, manufacturing time, and labor in order to convert affected stabilizing brace-related products into items not affected by the Rule. *Id.* ¶ 16.

68. B&T may also be forced to destroy or modify some of its products in their entirety because ATF is retroactively applying the GCA to prohibit all newly covered firearms assembled with imported parts, without the option to “cure” the violation by modifying the weapon. *Id.* ¶ 17; *accord* Rule, 88 Fed. Reg. at 6,564 (alterations accepted) (“[M]odification of this kind of firearm through the removal of the relevant parts would not cure the 922(r) violation because the ‘assembly’ has already occurred.”).

69. B&T’s reputation has also suffered as a result of many of its products unexpectedly triggering onerous federal firearms regulations. Luce Decl. ¶ 18.

70. These injuries are directly caused by ATF’s unlawful Rule and Adjudications. *Id.* ¶¶ 9–19.

71. These injuries would be redressed by an order of this Court setting aside the Rule and Adjudications. *Id.* ¶ 19.

72. These injuries are ongoing and irreparable.

FRAC’S ASSOCIATIONAL STANDING

73. FRAC has associational standing to bring suit on behalf of its members because “(a) its members would otherwise have standing to sue in their own right; (b) the interests it seeks to protect are germane to the organization’s purpose; and (c) neither the claim asserted nor the relief requested requires the participation of individual members in the lawsuit.” *Hunt v. Washington State Apple Advert. Comm’n*, 432 U.S. 333, 343 (1977).

74. *First*, at least two of FRAC’s members—SB Tactical and B&T—have standing. *See Warth v. Seldin*, 422 U.S. 490, 511 (1975) (to establish standing, “association must allege that its members, or any one of them, are suffering immediate or threatened injury”); *accord* Declaration of Travis White, ¶ 16 (“White Decl.”), attached as Ex. I; Creamer Decl. ¶¶ 38–48; Luce Decl. ¶¶ 9–19.

75. *Second*, putting a stop to ATF’s unlawful actions is germane to FRAC’s organizational purpose of protecting the firearms industry from “government overreach” and “holding the government accountable for arbitrary and capricious policies.” *See* Our Mission, FRAC, <https://www.fracaction.org/mission> (last visited Jan. 31, 2023); *accord* White Decl. ¶¶ 5, 7, 15, 23.

76. *Third*, neither the claims asserted nor the relief requested require the participation of individual members because Plaintiffs “seek[] only declaratory and prospective injunctive relief.” *Heartland Acad. Cmty. Church v. Waddle*, 427 F.3d 525, 533 (8th Cir. 2005).

RICHARD CICERO’S STANDING

77. Richard Cicero owns multiple stabilizing braces. Declaration of Richard Cicero, ¶ 24 (“Cicero Decl.”), attached as Ex. J.

78. Because of injuries sustained serving his country in Afghanistan—including the loss of two limbs, traumatic brain injury (“TBI”), and loss of strength and dexterity in his left hand—Mr. Cicero must use these stabilizing braces to safely fire many kinds of pistols. *Id.* ¶¶ 4–5; *see also* Comments of Richard Cicero (Attachments B and C omitted) (“Cicero Comments”), attached as Ex. F.

79. Mr. Cicero is injured by ATF’s unlawful Rules and Adjudications because he will now be forced to either give up on shooting pistols that bring him joy and to which he is entitled under the Second Amendment of the U.S. Constitution, or become subject to extensive federal firearms regulations. Cicero Decl. ¶¶ 24–27; *see Lujan v. Defs. of Wildlife*, 504 U.S. 555, 561–62 (1992)

(“little question” that plaintiff suffers injury when he is “the object of the government action or inaction he challenges”).

80. Because of Mr. Cicero’s TBI and the loss of dexterity in his left hand—the result of his service in Afghanistan—registering these six firearms under the NFA is simply too onerous of a task for him to complete. *Id.* ¶ 25.

81. Because registration is not a viable option for Mr. Cicero, he intends to have a local dealer disassemble his braced pistols and refit them with longer barrels to avoid the pistols being classified as short-barreled rifles. *Id.* ¶ 26.

82. As a result, Mr. Cicero will not be able to as easily or safely use his firearms. *Id.* ¶ 27.

83. Under the Rule, Mr. Cicero must modify his firearms within 120 days or risk criminal liability. *See* Rule, 88 Fed. Reg. at 6,553.

84. Mr. Cicero’s injury is directly caused by ATF’s unlawful Rule and Adjudications. Cicero Decl. ¶¶ 23–27, 31.

85. This injury would be redressed by an order of this Court setting aside the Rule and Adjudications. *Ibid.*

86. This injury is imminent and irreparable.

STATES’ STANDING

87. ATF’s unlawful Rule provides that “[s]hould States or political subdivisions of the States (for example, local police departments) possess weapons with ‘stabilizing braces’ that constitute unregistered short-barreled rifles, these firearms must be registered.” Rule, 88 Fed. Reg. at 6,567.

88. Law enforcement officers and agents in the Plaintiff States frequently possess or carry pistol stabilizing braces in law enforcement vehicles to be better prepared to respond to potential threats and emergency situations. In fast-moving and often dangerous situations, officers may not have adequate time to obtain a different firearm. Accordingly, pistol stabilizing braces, which can

help with safer and more accurate firing when officers are armed only with a handgun, provide significant law-enforcement and public-safety benefits.

89. Because the State Plaintiffs are subject to regulation by ATF and will have to incur compliance costs to ensure that all weapons possessed by their law enforcement officers are in accord with ATF's new Rule, they have suffered injury in fact. *See Lujan*, 504 U.S. at 561–62; *Nebraska v. Biden*, 52 F.4th 1044, 1047 (8th Cir. 2022) (“threatened financial harm to the State” is “injury in fact”). In addition, the State Plaintiffs will incur financial costs for every weapon the Rule requires them to register. Rule, 88 Fed. Reg. at 6,567 (estimating that it will take State officials “30 minutes to” register firearms “with a loaded wage rate of \$49.67, making the per application burden \$25”).

90. Moreover, there are within multiple of the Plaintiff States firearm manufacturers (or dealers) that make (or sell) pistol stabilizing braces and/or pistols affixed with stabilizing braces. The consequences of ATF's unlawful Rule to such manufacturers (or dealers) include, among other things, inhibiting these entities from making and selling pistol stabilizing braces and/or pistols affixed with stabilizing braces. This would not only harm such manufacturers' businesses but also deprive Plaintiff States of sales (or other) tax revenue for every stabilizing brace and/or pistol affixed with stabilizing brace not made or sold that, but for ATF's unlawful Rule, would have been made or sold.

91. These injuries are directly caused by ATF's unlawful Rule and Adjudications.

92. These injuries would be redressed by an order of this Court setting aside the Rule and Adjudications.

93. These injuries are imminent and irreparable.

BACKGROUND

THE NATIONAL FIREARMS ACT AND THE GUN CONTROL ACT

94. The Government regulates firearms primarily through two federal statutes: the National Firearms Act (“NFA”), 26 U.S.C. §§ 5841–72, and the Gun Control Act (“GCA”), 18 U.S.C. §§ 921–31.

95. Firearms carry with them a regulatory burden that corresponds to their classification under these two statutes.

96. Because the NFA enumerates the specific “firearms” to which it applies, most guns—including rifles, shotguns, and pistols—are not NFA regulated. Those that are NFA-regulated are subject to burdensome tax and registration requirements backed by criminal penalties.

97. The GCA regulates the business of importing, manufacturing, or dealing in firearms generally. In addition, the GCA imposes heightened restrictions on the transportation, sale, and delivery of any “short-barreled rifle,” “short-barreled shotgun,” or “machinegun.” 18 U.S.C. § 922(a)(4), (b)(4).

Congress imposed restrictions on certain short-barreled guns.

98. In the late 1920s and early 1930s, organized crime was becoming “a major national problem.” *Lomont v. O’Neill*, 285 F.3d 9, 11 (D.C. Cir. 2002).

99. “[T]he country struggled to control the violence wrought by ‘gangsters, racketeers, and professional criminals.’” *Bezot v. United States*, 276 F. Supp. 3d 576, 611 (E.D. La. 2017), *aff’d*, 714 F. App’x 336 (5th Cir. 2017).

100. Congress thus enacted the NFA to regulate “weapons likely to be used for criminal purposes.” *Thompson/Ctr. Arms Co.*, 504 U.S. at 517 (plurality opinion).

101. Because these lawbreakers favored “machine gun[s]” and “sawed-off guns,” H.R. Rep. No. 73-1780, Congress determined to regulate these “dangerous” weapons.

102. With respect to sawed-off guns, Congress believed that “a long gun with a shortened barrel is both dangerous, because its concealability fosters its use in illicit activity, and unusual, because of its heightened capability to cause damage.” *United States v. Cox*, 906 F.3d 1170, 1185 (10th Cir. 2018) (cleaned up); *accord United States v. Marzzarella*, 614 F.3d 85, 95 (3rd Cir. 2010).

103. At the same time, however, Congress found these dangers did not accompany “pistols and revolvers and sporting arms,” and thus declined to regulate those guns. H.R. Rep. No. 73-1780.

104. The result of these policy choices is the scheme in place today: the NFA and the GCA impose significant restrictions on short-barreled rifles, but generally do not impose significant regulatory burdens on pistols and other weapons that are not specifically enumerated in the statutes.

A weapon is subject to varying restrictions and burdens based on its classification.

105. The NFA. A weapon classified as a “firearm” under the NFA is subject to extensive federal regulation.

106. Reflecting Congress’s desire to regulate dangerous sawed-off weapons, the NFA defines “firearm” to reach “a weapon *made from a rifle* if such weapon as modified has an overall length of less than 26 inches or a barrel or barrels of less than 16 inches in length.” 26 U.S.C. § 5845(a)(4) (emphasis added).

107. “Rifle” is in turn defined to mean “a weapon designed or redesigned, made or remade, and intended to be fired from the shoulder and designed or redesigned and made or remade to use the energy of the explosive in a fixed cartridge to fire only a single projectile through a rifled bore for each single pull of the trigger, and shall include any such weapon which may be readily restored to fire a fixed cartridge.” 26 U.S.C. § 5845(c).

108. Although the “made from a rifle” definition captures the principal evil Congress sought to address—criminals buying long guns and sawing them down—it creates a loophole where a criminal could buy a gun with a shortened barrel directly from a licensed manufacturer. This is because the definition’s operative term “made” excludes “manufacturing . . . by one qualified to engage in such business under” the NFA. 26 U.S.C. § 5845(i).

109. Congress thus defined “firearm” to also reach “a rifle having a barrel or barrels of less than 16 inches in length.” 26 U.S.C. § 5845(a)(3). This provision reaches the original manufacturing omitted by the “made from a rifle” provision.

110. Taken together, the NFA definition of “firearm” reaches all originally-manufactured short-barreled rifles and all short-barreled rifles “made from a rifle.”

111. Inclusion within the NFA’s definition of a “firearm” carries significant legal and regulatory consequences.

112. Anyone who makes an NFA firearm must submit an application to ATF with identifying information—including his fingerprints and a passport photo—and must pay a \$200 tax. 26 U.S.C. § 5822; 27 C.F.R. §§ 479.61, 479.62; *see also* ATF Form 1 – Application to Make and Register a Firearm, <https://www.atf.gov/firearms/docs/form/form-1-application-make-and-register-firearm-atf-form-53201>.

113. Anyone who transfers an NFA firearm must also submit an application to ATF with identifying information and must pay an additional \$200 tax. 26 U.S.C. § 5812; 27 C.F.R. §§ 479.66, 479.84.

114. Anyone who receives an NFA firearm must provide ATF with his fingerprints and notify his local police department of the transfer. 26 U.S.C. § 5812; 27 C.F.R. §§ 479.84(c), 479.85.

115. Anyone possessing an NFA firearm must register himself and his NFA firearm in a

federal database. 26 U.S.C. § 5841; 28 C.F.R. § 0.131(d); 27 C.F.R. §§ 479.101, 479.102.

116. Anyone who violates the NFA may be imprisoned for up to ten years and fined up to \$10,000. 26 U.S.C. § 5871.

117. The GCA. A weapon classified as a short-barreled rifle under the GCA is subject to statutory rules governing its sale, delivery, and interstate transportation.

118. Similar to the NFA’s definition of “firearm,” the GCA defines “short-barreled rifle” as “a rifle having one or more barrels less than sixteen inches in length” and as “any weapon made from a rifle (whether by alteration, modification, or otherwise) if such weapon, as modified, has an overall length of less than twenty-six inches.” 18 U.S.C § 921(a)(8).

119. “Rifle” is in turn defined as “a weapon designed or redesigned, made or remade, and intended to be fired from the shoulder and designed or redesigned and made or remade to use the energy of an explosive to fire only a single projectile through a rifled bore for each single pull of the trigger.” *Id.* § 921(a)(7).

120. The GCA’s rules applicable to short-barreled rifles and other firearms often turn on whether the relevant actor holds a federal firearms license (“FFL”)—i.e., a license issued by the Attorney General “to transport, ship, and receive firearms and ammunition covered by such license in interstate or foreign commerce during the period stated in the license.” 18 U.S.C. § 923(c); *accord* 27 C.F.R. § 478.41.

121. Individuals may “engage in the business of importing, manufacturing, or dealing in firearms” only if they hold an FFL. 18 U.S.C. § 922(a)(1)(A).

122. FFL holders may “sell or deliver” short-barreled rifles to unlicensed persons only “as specifically authorized by the Attorney General consistent with public safety and necessity.” 18 U.S.C. § 922(b)(4); 27 C.F.R. § 478.98.

123. Unlicensed individuals may “transport” short-barreled rifles “in interstate or foreign commerce” only “as specifically authorized by the Attorney General consistent with public safety and necessity.” 18 U.S.C. § 922(a)(4); *see also* 27 C.F.R. § 478.28.

124. Entities or individuals who sell, deliver, or transport short-barreled rifles without a required authorization from the Attorney General may be imprisoned for up to five years and fined up to \$500,000. 18 U.S.C. §§ 924(a)(1)(B), (D); 3571(c)(3); 3559(a)(4).

125. ATF allows—but does not require—parties to submit products for classification under the NFA and GCA. *See* 27 C.F.R. § 478.92(c) (explaining that process is “voluntary”). When a party obtains such a classification, it is “authoritative” as to the classified product. *See id.* While ATF formally codified its classification process last year, the agency employed it “[f]or many years” prior to codification. Definition of “Frame or Receiver” and Identification of Firearms, 86 Fed. Reg. 27,720, 27,733 (May 21, 2021) (Proposed Rule); *accord Sig Sauer, Inc. v. Brandon*, 826 F.3d 598, 600 n.1 (1st Cir. 2016) (explaining that parties are bound by ATF classification letters). ATF’s classification letters thus carried enormous consequences in terms of the public’s understanding of whether a firearm was or was not subject to the NFA and GCA.

PISTOL STABILIZING BRACES

Stabilizing braces are a popular accessory that help shooters fire pistols and other firearms more safely and accurately.

126. In 2012, SB Tactical’s co-founder Alex Bosco—a Marine Corps and Army veteran—invented the original Pistol Stabilizing Brace®.

127. Bosco was shooting with his friend—a disabled combat veteran—when the range master asked Bosco’s friend to stop firing because of safety concerns due to his lack of control over the gun.

128. Determined to help his friend and other wounded combat veterans, Bosco had an idea.

He produced the first Pistol Stabilizing Brace prototype in his garage.

129. As the original Pistol Stabilizing Brace patent shows, these devices secure the pistol to a shooter's forearm in order to stabilize firing:³

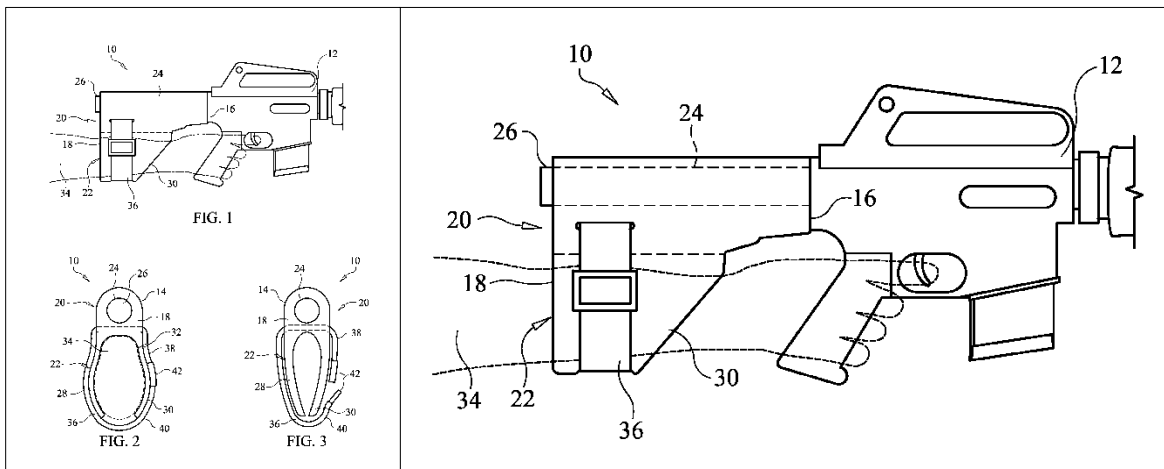

130. Through this design, braces are orthotic devices that allow users to more safely and accurately fire handguns. *See* Report of Gabriel Hurst, Certified Prosthetist/Orthotist, at 1 (Sept. 7, 2021) (originally appended to FRAC comments) (“Hurst Report”), attached as Ex. K. Indeed, SB Tactical’s brace design—“a strap and a cuff made of an elastomer material”—mimics well-established orthotic devices, such as “[t]he forearm crutch,” which “has been in use for close to 70 years.” *Id.* at 1–2.

131. SB Tactical’s brace design has been remarkably successful in achieving its goal of allowing individuals with disabilities to safely fire weapons.

132. As Plaintiff Richard Cicero told ATF, he “lost an arm and a leg” after being “injured on a foot patrol in Afghanistan,” making it incredibly difficult for him to safely fire weapons. Cicero Comments at 1. But after the first brace “was created,” “a world of opportunity opened for [him].” *Ibid.* Indeed, stabilizing braces were “the birth of [his] teaching so many others to shoot again.”

³ *See* U.S. Patent No. 8,869,444 B2 (issued Oct. 28, 2014), <https://patentimages.storage.googleapis.com/0e/ef/63/3020eaabf1d854/US8869444.pdf>.

Ibid.

133. In fact, stabilizing braces have allowed “thousands of injured shooters to return to [a] safe fulfilling hobb[y],” “improv[ing] [their] quality of life.” *Id.* at 2.

134. For example, one of Mr. Cicero’s “hundreds” of students—a veteran who “lost his arm while serving in the United States Air Force”—“went on to become the first one armed correctional officer in his home state” after Mr. Cicero “taught [him] to shoot a pistol with a stabilizing brace.” Cicero Decl. ¶ 18.

135. Stabilizing braces are also popular with individuals that do not have physical disabilities and who use braces to “more safely use” “firearms,” particularly “beginning shooters and shooters with less physical strength.” Cicero Comments at 2.

136. Some of these able-bodied shooters may nevertheless have “limited mobility” or “limited body strength” such that they “simply cannot use a firearm safely and effectively” “[w]ithout a stabilizing brace.” Cicero Decl. ¶ 15.

137. Stabilizing braces are also common for state law enforcement officers and agents who frequently possess or carry the braces to assist in emergency preparedness when armed only with their handgun.

138. Stabilizing braces thus provide users of all stripes a more stable firing platform to increase safety and accuracy.

139. All told, *millions* of Americans have purchased stabilizing braces to achieve safer and more accurate firing. *See* Rule, 88 Fed. Reg. at 6,560 (estimating that there are “3 million ‘stabilizing braces’ and firearms with an attached ‘stabilizing brace’ currently in circulation”); William J. Krouse, *Handguns, Stabilizing Braces, and Related Components*, Congressional Research Service (Apr. 19, 2021), <https://crsreports.congress.gov/product/pdf/IF/IF11763> (“there

are between 10 and 40 million stabilizing braces and similar components already in civilian hands”); *accord* Comments of the National Shooting Sports Foundation, at 7 (filed Sept. 7, 2021) (noting that Congressional Research Service “estimate is more in line with [industry]’s estimate” derived from “the market and input from” companies);⁴ Report of Todd D. Kendall, Ph.D, Compass Lexicon, at 24 (Sept. 7, 2021) (originally appended to FRAC comments), attached as Ex. T.

For more than a decade, ATF tells the public that stabilizing braces do not change the regulatory classification of pistols and other firearms

140. Before SB Tactical brought its stabilizing brace to market, it procured a classification letter from ATF concluding that attaching a stabilizing brace “would not alter the classification of a pistol or other firearm” and that “such a firearm *would not be* subject to NFA controls.” Rule, 88 Fed. Reg. at 6,479 (quoting Letter from ATF #2013-0172 (Nov. 26, 2012) (emphasis in original letter); *see also* FTB Letter 2013-0172 (Nov. 26, 2012), attached as Ex. L. Furthermore, ATF recognized that a stabilizing brace differs from a shoulder stock because a “‘brace,’ when attached to a firearm, d[oes] ‘not convert that weapon to be fired from the shoulder.’” *Ibid.*

141. By determining that a brace-equipped pistol was not a short-barreled rifle designed and intended to be fired from the shoulder, ATF did not subject such weapons to the onerous controls of the NFA and GCA.

142. As a result, an individual was free to use a stabilizing brace to more safely and accurately fire his gun without providing ATF with his fingerprints, 26 U.S.C. § 5812(a)(3); subjecting himself to registration in a federal database, *id.* 5841(b); obtaining a “specific[] authoriz[ation] by the Attorney General” before transferring the short-barreled rifle across state lines, 18 U.S.C.

⁴ <https://www.regulations.gov/comment/ATF-2021-0002-181221>.

§ 922(a)(4); and complying with other requirements.

143. ATF repeatedly reaffirmed its position over the years. Following its 2012 classification, ATF issued at least 17 classification letters opining that different stabilizing brace designs did not convert pistols into short-barreled rifles. Rule, 88 Fed. Reg. at 6,502 & n.84.

144. In 2014, ATF even ruled that “firing a pistol [equipped with a brace] from the shoulder would *not* cause the pistol to be reclassified.” FTB Letter 301737 at 1 (Mar. 5, 2014), attached as Ex. M.

145. While ATF issued some classification letters finding that products changed a pistol’s regulatory classification, those letters focused on whether the product in fact functioned as a brace. When, unlike SB Tactical’s brace designs, these products did not secure the weapon to a shooter’s arm with two elastomeric flaps and a strap, ATF determined that the firearm was a short-barreled rifle.

146. For example, in 2014, ATF found that adding a “foam padded stabilizer tube”—i.e., a length of padding with no flaps or other mechanism to secure the weapon to the forearm—to a pistol “would result in the manufacture of a ‘short-barreled rifle.’” Rule, 88 Fed. Reg. at 6,485.

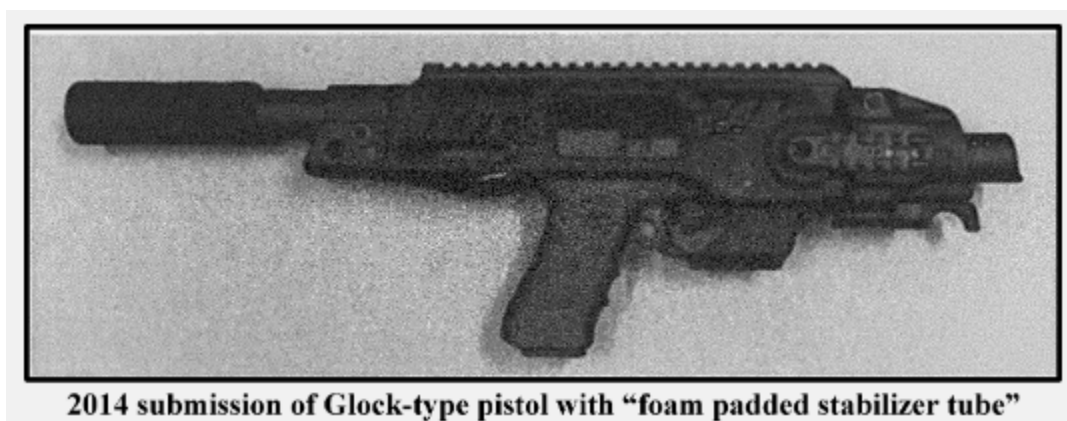

147. By contrast, ATF found that stabilizing braces like the ones manufactured by SB Tactical—i.e., that used two elastomeric flaps and a strap to wrap around the shooter’s arm—did

not change a pistol's regulatory classification under the NFA or GCA, exactly because they functioned as a brace and were not intended to be fired from the shoulder.

148. For example, in 2015, ATF found that attaching SB Tactical's adjustable stabilizing brace product to a pistol "would not be a 'short-barreled rifle.'"⁵ Rule, 88 Fed. Reg. at 6,488; *see also* ATF Letter 304296 (Dec. 22, 2015), attached as Ex. N.



2015 submission of "adjustable stabilizing brace"

149. ATF also issued an open letter in 2015 again asserting its position that a stabilizing brace "may be attached to a handgun without making a[n] NFA firearm." ATF, Open Letter on the Redesign of Stabilizing Braces at 2 (Jan. 16, 2015), attached as Ex. O.

150. ATF also took the same position in criminal prosecutions, advising courts that attaching stabilizing braces to a weapon would not create a short-barreled rifle subject to additional regulation under federal statutes. In a 2019 sentencing hearing, for example, the Government told a federal judge: "the type of device placed on the firearm is also dispositive of what type of firearm, whether it's a rifle or whether it is a pistol and so the ATF letters do correctly state that they consider a firearm with a pistol brace to not be a rifle under the NFA for purposes of the NFA." Sentencing Hr'g Tr. at 38:9-15, *United States v. Kamali*, Case No. 18-cr-288, Dkt. # 110 (Sept.

⁵ ATF conditioned this conclusion on SB Tactical not incorporating raised ridges on the rear of the brace, Rule, 88 Fed. Reg. at 6,448, and SB Tactical complied with this condition.

24, 2019) (“Kamali Transcript”), attached as Ex. P.

151. ATF’s representations to the public were in accord. In 2017, it issued a letter opining that it was “clear that stabilizing braces are *perfectly legal accessories* for large handguns or pistols.” See ATF Letter 5000, at 1 (Mar. 21, 2017) (emphasis added), attached as Ex. Q.

152. Of course, ATF did not say that it would accept without question that any item attached to the back of a pistol was a stabilizing brace. But it stood by its prior classification letters finding that stabilizing braces like those produced by SB Tactical—i.e., that secured the shooter’s arm to the weapon using two elastomeric flaps and a strap—were not designed and intended to facilitate shoulder-firing.

153. Unsurprisingly, ATF’s classification decisions and its 2017 declaration that stabilizing braces were “perfectly legal accessories” led many law-abiding Americans to buy stabilizing braces in order to facilitate safer and more accurate shooting. See Rule, 88 Fed. Reg. at 6,560 (explaining that “demand and production for ‘stabilizing braces’ . . . t[ook] off” in “2017”).

154. For years, ATF also repeatedly represented to Plaintiff SB Tactical’s attorneys that there were no issues with any of SB Tactical’s products. See Creamer Decl. ¶¶ 36–37; SB Tactical Response Letter to ATF’s Preliminary Classification of the SBA3 (Mar. 13, 2020), attached as Ex. S.

155. In 2020, ATF issued a Notice suggesting that ATF was considering a change in its approach to regulating stabilizing braces. See *Objective Factors for Classifying Weapons with “Stabilizing Braces,”* Notice, 85 Fed. Reg. 82,516 (Dec. 18, 2020).

156. But two weeks later—after receiving a deluge of comments in opposition to ATF’s proposed change—ATF publicly withdrew that notice and clarified that it was not “chang[ing] any law, regulation, or other legally binding requirement.” *Objective Factors for Classifying Weapons*

With “Stabilizing Braces”; Withdrawal of Guidance, Withdrawal, 85 Fed. Reg. 86,948 (Dec. 31, 2020).

157. ATF’s reaffirmance of the regulatory status quo reinforced the perception that stabilizing braces did not change the classification of the guns to which they were affixed.

158. As many observed, ATF’s position “created a thriving market for these stabilizing braces.” Letter from the Honorable Mitch McConnell, et al. to the Honorable Merrick Garland at 2 (June 24, 2021) (originally appended to FRAC Comments), attached as Ex. R.

ATF changes its mind.

159. Without any legislative change, the President of the United States ordered ATF to abandon a decade of practice under an established statutory framework and “to treat pistols modified with stabilizing braces” as “subject to the National Firearms Act.” President’s Remarks on Gun Violence Prevention Efforts, 2021 Daily Comp. Pres. Doc. 298, at 3 (Apr. 8, 2021).

160. As a result, ATF initiated the rulemaking at issue in this case.

161. On June 10, 2021, ATF issued a Notice of Proposed Rulemaking which attempted to reconcile ATF’s previous classification letters by “assign[ing] point values” to “characteristics or features” that it considered probative of an intent to shoulder. *See* Factoring Criteria for Firearms with Attached “Stabilizing Braces,” Notice of Proposed Rulemaking, 86 Fed. Reg. 30,826, 30,829 (June 10, 2021) (“Notice”).

162. The Notice would have subjected to heightened regulation many brace-equipped guns that the agency previously had determined were not an NFA “firearm” or a GCA “short-barreled rifle,” but ATF also expressly found that some guns equipped with popular braces—such as SB Tactical’s SB-Mini—would still “be classified as a pistol with an attached ‘stabilizing brace’ accessory.” *Id.* at 30,837.

163. Because the overall effect of the proposal would have been to permit ATF to subject

more weapons to regulation as NFA firearms or GCA short-barreled rifles, ATF received significant pushback on its change, with “over 217,000 comments opposed to aspects of the rule” out of a total of 237,000. Rule, 88 Fed. Reg. at 6,497.

164. Many of these comments faulted the agency for using a point system that “w[as] not easily understood or applied” and which used terms that “were ambiguous and subject to interpretation,” giving ATF too much discretion. *Id.* at 6,513.

165. Ultimately, ATF “agree[d] with commenters” and decided to scrap its worksheet and adopt a new approach. *Ibid.*

ATF’S RULE

166. On January 31, 2023, ATF issued the Rule at issue in this case.

167. The Rule immediately invalidates every prior stabilizing brace classification issued by ATF. Rule, 88 Fed. Reg. at 6,480.⁶

168. In their place, the Rule adopts a new regulatory definition of “rifle” that incorporates an amorphous multi-factor test. *Id.* at 6,574–75 (to be codified at 27 C.F.R. § 478.11 and 27 C.F.R. § 479.11).

169. The test proceeds in two steps to determine whether a brace-equipped pistol is in fact a rifle. First, ATF will assess whether the brace “provides surface area that allows the weapon to be fired from the shoulder.” *Id.* at 6,575. Second, ATF will assess whether six “other factors . . . indicate that the weapon is designed, made, and intended to be fired from the shoulder.” *Ibid.* These six factors are (1) weight and length, (2) length of pull, (3) sights or scope, (4) whether the

⁶ Confusingly, the Rule first claims that “prior classifications are no longer valid as of January 31, 2023.” Rule, 88 Fed. Reg. at 6,480. It then asserts that “prior classifications are no longer valid as of May 31, 2023.” *Id.* at 6,502, 6,512. Given the felony consequences that attach to any misinterpreted ambiguity, Plaintiffs have no choice but to assume the earlier date.

brace is necessary for the gun’s cycle of operations, (5) marketing materials, and (6) information from “the general community.” *Ibid.*

170. Although this test is nominally “dependent on the specific configuration of the firearm,” *id.* at 6,507, ATF already predicts that it will encompass **99%** of all stabilizing braces, Regulatory Analysis at 21 (“there may be approximately 1 percent of ‘stabilizing braces’ that, when attached to the firearm, would not result in a firearm that is designed and intended to be fired from the shoulder”). ATF describes an example of an accessory that would not convert a pistol to a short-barreled rifle, Rule, 88 Fed. Reg. at 6,529–30 (“For example, an elastic strap that wraps around the shooter’s wrist and buffer tube on an AR-type firearm is an attachment that does not provide surface area to shoulder fire a weapon.”), but it does not point to a single firearm configuration or product actually in existence that would not trigger heightened regulation under the NFA and GCA.

171. The market has responded in kind, with the largest online gun marketplace now requiring **all** guns equipped with stabilizing braces to be listed as short-barreled rifles.⁷

172. By ATF’s estimate, **millions** of Americans have been committing felony gun crimes— with ATF’s full knowledge and express approval—for the past decade. Rule, 88 Fed. Reg. at 6,560 (estimating “3 million ‘stabilizing braces’ and firearms with an attached ‘stabilizing brace’ currently in circulation”).

173. However, ATF’s numbers understate the scope of the problem the Rule creates because the agency’s estimate arbitrarily stops at 2020. *See* Regulatory Analysis at 18 (estimating braces sold “between the years 2013 to 2020”). Indeed, based on SB Tactical’s sales from 2020 through

⁷ <https://support.gunbroker.com/hc/en-us/articles/12595908898459-New-ATF-Stabilizing-Brace-Rule>.

2023 alone, ATF’s estimate is short by more than 2.3 million braces. Creamer Decl. ¶ 15. And that does not account for sales by other brace manufacturers.

174. The Rule is effective immediately. Rule, 88 Fed. Reg. at 6,478.

175. Parties in possession of a brace-equipped gun have until May 31, 2023 to register their gun, destroy it, permanently modify it, or surrender it to ATF. *Id.* at 6,480. But to facilitate this “120-day registration period,” ATF must rely on “its enforcement discretion” because the agency’s position is that the millions of Americans in possession of these brace-equipped weapons have *already* committed the felony. *Id.* at 6,480–81.

176. “Notwithstanding the 120-day compliance period,” however, “the rule is immediately effective in that the Department may seek to enforce the NFA’s requirements with respect to any new making or new transfer of a weapon with an attached ‘stabilizing brace’ that constitutes a short-barreled rifle under the NFA.” *Id.* at 6,481.

THE RULE IS UNLAWFUL

177. In ATF’s single-minded quest “to treat pistols modified with stabilizing braces” as “subject to the National Firearms Act,” President’s Remarks on Gun Violence Prevention Efforts, 2021 Daily Comp. Pres. Doc. 298, at 3 (Apr. 8, 2021), it fails to heed the statutory text by which it is bound.

178. The NFA and GCA’s statutory definitions do not reach pistols equipped with stabilizing braces. The statutes cover weapons manufactured as short-barreled rifles, 26 U.S.C. § 5845(a)(3), and “weapon[s] made from a rifle,” *id.* § 5845(a)(4); *accord* 18 U.S.C. § 921(a)(8). Contrary to the Rule, the statutes do *not* cover guns manufactured as weapons other than short-barreled rifles or short-barreled guns made from weapons other than rifles.

179. The statutory purpose confirms this result. Congress enacted the NFA (and later, the GCA) to regulate the shortening of long firearms in a manner that makes them more attractive to

criminals because of their increased concealability and indiscriminate accuracy. The Rule, by contrast, regulates the lengthening of pistols and other short firearms through the attachment of accessories designed as orthotics that make these weapons *less* concealable, *more* accurate, and *less* dangerous, thereby undermining public safety.

180. The Rule is thus unambiguously foreclosed by the text, history, and purpose of the NFA and GCA.

181. The Rule also neglects the principal statutory definitions that enumerate the weapons covered by the NFA and subject to stricter controls under the GCA.

182. ATF misapprehends the term “designed” as used in 26 U.S.C. § 5845(c) and 18 U.S.C. § 921(a)(7). The Rule considers “*irrelevant*” evidence “that the ‘stabilizing brace’ makes firing a standard pistol more accurate or more enjoyable.” Rule, 88 Fed. Reg. at 6,557 (emphasis added). This is first and foremost directly contrary to ATF’s approach through the last decade and up through enactment of the Notice. But more importantly, “items which are principally used for non[-shouldering] purposes” are not “designed” for shouldering. *Village of Hoffman Estates v. Flipside, Hoffman Estates, Inc.*, 455 U.S. 489, 501 (1982). Thus, ATF cannot read the term “designed” to exclude all evidence showing that a stabilizing brace is suitable for use as a brace.

183. ATF also misinterprets “intended” as used in 26 U.S.C. § 5845(c) and 18 U.S.C. § 921(a)(7). ATF purports to divine intent from third-party marketing materials and “information.” Rule, 88 Fed. Reg. at 6,575. But third parties’ “opinion[s]” have no “conceivable relevance to the intent of the seller.” *Record Head Corp. v. Sachen*, 682 F.2d 672, 677 (7th Cir. 1982). Thus, like its interpretation of “designed,” the Rule’s interpretation of “intended” violates the NFA.

184. At the very least, the NFA is grievously ambiguous as applied to pistols equipped with stabilizing braces, as evidenced by ATF reading the statute to not cover these weapons for more

than a decade. Under these circumstances, the rule of lenity requires excluding brace-affixed weapons from the scope of the NFA. See *Thompson/Ctr. Arms Co.*, 504 U.S. at 517–18 (1992) (plurality) (applying rule of lenity to prevent NFA regulation of pistol sold with a shoulder stock and a 21-inch barrel); *id.* at 519 (Scalia, J., concurring); *Cargill*, 57 F.4th at 469–71 (5th Cir. 2023) (applying rule of lenity to prevent NFA and GCA regulation of bump stocks).

185. ATF’s Rule also construes the statute in a way that would raise grave constitutional doubts under the Second Amendment. With millions of stabilizing braces in circulation—even by ATF’s conservative estimate—braced weapons are plainly in “common use” and thus protected by the Second Amendment. *New York State Rifle & Pistol Ass’n, Inc. v. Bruen*, 142 S. Ct. 2111, 2128, 2143 (2022); see *Avitabile v. Beach*, 368 F. Supp. 3d 404, 411 (N.D.N.Y. 2019) (concluding that “at least 300,000 tasers and 4,478,330 stun guns owned by private citizens across the United States” constituted “common use”); *Maloney v. Singas*, 351 F. Supp. 3d 222, 237–38 (E.D.N.Y. 2018) (“The Court finds that based on this magnitude of sales . . . [that] Defendant has failed to establish that nunchaku are not in common use.”). The doctrine of constitutional avoidance thus requires reading the NFA and the GCA to avoid placing onerous restrictions on these weapons. See *Union Pac. R.R. Co. v. DHS*, 738 F.3d 885, 893 (8th Cir. 2013).

186. The Rule is also hopelessly unworkable. For example, the Rule says that ATF will first assess whether a brace “provides surface area that allows the weapon to be fired from the shoulder.” Rule, 88 Fed. Reg. at 6,575.

187. But that inquiry raises an obvious question: *how much* “surface area” “allows the weapon to be fired from the shoulder?” ATF—without giving a reason—declines “to specify a quantifiable metric for what constitutes surface area that allows for shouldering of the weapon” and will not “attempt to precisely measure or quantify the surface area.” Rule, 88 Fed. Reg. at

6,529.

188. ATF's other factors fare no better. For example, ATF says that it will assess whether brace-affixed pistols have a weight, length, and length of pull that are "consistent with" "similarly designed rifles." Rule, 88 Fed. Reg. at 6,575.

189. But ATF does not provide a comprehensive list of "similarly designed rifles" and instead offers a handful of examples, leaving to regulated parties the impossible task of figuring out which rifles ATF will use as benchmarks from a population of at least "12,000 firearms." *Id.* at 6,514–19, 6,535–38 & n.103. ATF also ignores evidence that many pistols have physical characteristics similar to the "rifles" it identifies as examples. Even if an individual manages to guess right, he or she then has to figure out whether his or her braced weapon's features are "consistent with" those benchmarks—a term that is undefined.

190. ATF also advises parties that it will look at "marketing and promotional materials," as well as "[i]nformation demonstrating the likely use of the weapon in the general community." Rule, 88 Fed. Reg. at 6,575. But ATF does not commit itself to any kind of standard for how it will weigh or assess this information. Indeed, the Preamble credits some individuals' characterizations of a brace while writing off others as anecdotal and not even "relevant." *Id.* at 6,519. Elsewhere, it divines from generic anti-establishment marketing slogans an unstated intent "to avoid NFA controls." *Id.* at 6,544.

191. ATF's factors are little more than window dressing for the agency to reach its preferred outcome.

192. ATF's Rule is also unlawful because it relies on a deficient cost-benefit analysis that, *inter alia*, arbitrarily fails to consider millions of stabilizing braces.

193. Finally, ATF's Rule is impermissibly retroactive in excess of its statutory authority under

the GCA.

ATF'S BRACE ADJUDICATIONS

194. Along with the Rule, ATF also issued dozens of adjudications purporting to classify as short-barreled rifles common firearms and weapon platforms equipped with the most popular stabilizing braces in the United States (“the Adjudications”). *See* ATF, Common Weapon Platforms with Attached ‘Stabilizing Brace’ Designs that are Short-Barreled Rifles (“Platforms Adjudication”), attached as Ex. C; ATF, Commercially Available Firearms Equipped with a ‘Stabilizing Brace’ that are Short-Barreled Rifles (“Firearms Adjudication”), attached as Ex. D.

195. These Adjudications contain no analysis and consist solely of photographs of brace-equipped firearms or weapons platforms labeled “Short-barreled Rifle.”

196. Like the underlying Rule, the Adjudications are completely untethered from the statutory text they purport to apply.

197. The Adjudications are also unlawful because they were issued contemporaneously with the Final Rule, and do not at all explain the reasons for the agency’s decisions.

198. The Adjudications confirm that ATF believes its Rule will allow it to achieve whatever outcome it wants, regardless of the facts before the agency. Take, for example, ATF’s adjudication of the SB-Mini. ATF has twice before issued preliminary classifications concluding that a pistol affixed with the SB-Mini is not a short-barreled rifle. *See* Rule, 88 Fed. Reg. at 6,492 (preliminary classification letter in 2020); Notice, 86 Fed. Reg. at 30,835–38 (example application of worksheet). Now, ATF says that it *is* a short-barreled rifle. *See* Platforms Adjudication at 8. That ATF felt no need to even explain *why* use of the SB-Mini results in a short-barreled rifle demonstrates that the Rule and its factors are nothing more than a legal veneer for ATF to do whatever it wants.

FIRST CLAIM FOR RELIEF
(Rule – Ultra Vires)

199. Plaintiffs incorporate by reference all prior paragraphs of this Complaint and the paragraphs in the counts below as though set forth fully herein.

200. The APA authorizes this Court to “hold unlawful and set aside agency action, findings, and conclusions found to be . . . arbitrary, capricious, an abuse of discretion, or otherwise not in accordance with law [or] in excess of statutory jurisdiction, authority, or limitations, or short of statutory right.” 5 U.S.C. § 706(2)(A), (C).

201. The Rule is a final agency action that exceeds ATF’s statutory authority.

202. The Rule regulates pistols and other firearms equipped with stabilizing braces, even though the text, structure, history, and purpose of the NFA and GCA show that the statute does not regulate such weapons.

203. The Rule misinterprets “designed” as used in 26 U.S.C. § 5845(c) and 18 U.S.C. § 921(a)(7) by, among other things, excluding from ATF’s future classification decisions all evidence showing that a stabilizing brace functions as a stabilizing brace.

204. The Rule misinterprets “intended” as used in 26 U.S.C. § 5845(c) and 18 U.S.C. § 921(a)(7) by, among other things, attributing third-party intent to firearms manufacturers, stabilizing brace manufacturers, commercial retailers and other sellers, and individual gun owners.

205. At minimum, the NFA and GCA are grievously ambiguous as applied to stabilizing braces, and thus the Rule violates the rule of lenity.

206. The Rule is invalid because it interprets the NFA and GCA in a way that encompasses millions of weapons—undoubtedly in common use—and thus raises grave constitutional doubts under the Second Amendment. *See Union Pac. R.R. Co.*, 738 F.3d at 893.

207. The Rule is impermissibly retroactive in excess of ATF’s statutory authority.

208. The Rule is invalid because it engages in impermissible hybrid rulemaking and adjudication.

SECOND CLAIM FOR RELIEF
(Rule – Arbitrary And Capricious)

209. Plaintiffs incorporate by reference all prior paragraphs of this Complaint and the paragraphs in the counts below as though set forth fully herein.

210. The APA authorizes this Court to “hold unlawful and set aside agency action, findings, and conclusions found to be . . . arbitrary, capricious, an abuse of discretion, or otherwise not in accordance with law.” 5 U.S.C. § 706(2)(A).

211. The Rule is arbitrary and capricious.

212. The factors adopted by the Rule are holistically arbitrary because they leave Plaintiffs, “other regulated parties, and reviewing courts[,] guessing” at how to apply the ATF’s purported standard and because they would confer unbounded discretion upon the agency and are otherwise inadequately explained. *Innovator Enters., Inc. v. Jones*, 28 F. Supp. 3d 14, 25 (D.D.C. 2014).

213. The factors adopted by the Rule are individually arbitrary because they do not meaningfully “articulate[] the standards that [will] guide[] [ATF’s] analysis” and because they are contrary to evidence in the record and otherwise inadequately explained. *Tripoli Rocketry Ass’n, Inc. v. ATF*, 437 F.3d 75, 81 (D.C. Cir. 2006).

214. The Rule’s consideration of costs and benefits is arbitrary and capricious.

THIRD CLAIM FOR RELIEF
(Adjudications – Ultra Vires)

215. Plaintiffs incorporate by reference all prior paragraphs of this Complaint and the paragraphs in the counts below as though set forth fully herein.

216. The APA authorizes this Court to “hold unlawful and set aside agency action, findings, and conclusions found to be . . . arbitrary, capricious, an abuse of discretion, or otherwise not in

accordance with law [or] in excess of statutory jurisdiction, authority, or limitations, or short of statutory right.” 5 U.S.C. § 706(2)(A), (C).

217. The Adjudications are final agency actions that exceed ATF’s statutory authority.

218. The Adjudications subject to NFA regulation and heightened GCA regulation pistols equipped with stabilizing braces, even though the text, structure, history, and purpose of the NFA and GCA show that the statutes do not reach such weapons.

219. The Adjudications misinterpret “designed” as used in 26 U.S.C. § 5845(c) and 18 U.S.C. § 921(a)(7), by excluding from consideration all evidence showing that a stabilizing brace functions as a stabilizing brace.

220. The Adjudications misinterpret “intended” as used in 26 U.S.C. § 5845(c) and 18 U.S.C. § 921(a)(7), by attributing third-party intent to firearms manufacturers, stabilizing brace manufacturers, commercial retailers and other sellers, and individual gun owners.

221. At minimum, the statutes and the Rule are grievously ambiguous as applied to stabilizing braces, and thus the Adjudications violate the rule of lenity.

222. The Adjudications are invalid because they interpret the NFA and GCA in a way that encompasses millions of weapons—undoubtedly in common use—and thus raises grave constitutional doubts under the Second Amendment. *See Union Pac. R.R. Co.*, 738 F.3d at 893.

223. The Adjudications are in excess of ATF’s statutory authority under the Administrative Procedure Act because ATF impermissibly issued them contemporaneously with the Rule.

FOURTH CLAIM FOR RELIEF
(Adjudications – Arbitrary And Capricious)

224. Plaintiffs incorporate by reference all prior paragraphs of this Complaint and the paragraphs in the counts below as though set forth fully herein.

225. The APA authorizes this Court to “hold unlawful and set aside agency action, findings,

and conclusions found to be . . . arbitrary, capricious, an abuse of discretion, or otherwise not in accordance with law.” 5 U.S.C. § 706(2)(A).

226. The Adjudications are arbitrary and capricious because they do not provide reasoned explanations.

FIFTH CLAIM FOR RELIEF
(Rule and Adjudications – Unconstitutionally Vague)

227. Plaintiffs incorporate by reference all prior paragraphs of this Complaint and the paragraphs in the counts below as though set forth fully herein.

228. The APA authorizes this Court to “hold unlawful and set aside agency action, findings, and conclusions found to be . . . arbitrary, capricious, an abuse of discretion, or otherwise not in accordance with law [or] contrary to constitutional right, power, privilege, or immunity.” 5 U.S.C. § 706(2)(A), (B).

229. The Rule and statute are unconstitutionally vague on their face and as applied in the Adjudications.

PRAYER FOR RELIEF

WHEREFORE, Plaintiffs respectfully request that this Court enter judgment in their favor and against Defendants, as follows:

- A. Declare unlawful and set aside ATF’s Rule and Adjudications.
- B. Preliminarily and permanently enjoin ATF from enforcing the Rule and Adjudications.
- C. Award Plaintiffs costs and attorneys’ fees pursuant to 28 U.S.C. § 2412.
- D. Grant such further and additional relief as this Court deems just and proper.

February 9, 2023

/s/ Stephen J. Obermeier
Stephen J. Obermeier
Thomas M. Johnson, Jr.
Michael D. Faucette
Jeremy J. Broggi
Boyd Garriott
WILEY REIN LLP
2050 M Street NW
Washington, DC 20036
Tel: 202.719.7000
Fax: 202.719.7049
SObermeier@wiley.law
TMJohnson@wiley.law
MFaucette@wiley.law
JBroggi@wiley.law
BGarriott@wiley.law

Benjamin J. Sand (ND ID #07981)
CROWLEY FLECK PLLP
100 W Broadway Ave
Bismarck, ND 58501
Tel: 701.223.6585
Fax: 701.222.4853
bsand@crowleyfleck.com

*Counsel for Plaintiffs FRAC, SB Tactical,
B&T, and Richard Cicero*

/s/ Lindsay See

PATRICK MORRISEY
Attorney General
LINDSAY SEE
Solicitor General
MICHAEL R. WILLIAMS
Senior Deputy Solicitor General

Office of the West Virginia Attorney General
State Capitol, Bldg 1, Room E-26
Charleston, WV 25305
(681) 313-4550
Lindsay.S.See@wvago.gov
Michael.R.Williams@wvago.gov

Counsel for Plaintiff State of West Virginia

DREW H. WRIGLEY
Attorney General
JAMES E. NICOLAI
Interim Solicitor General

North Dakota Attorney General's Office
600 E Boulevard Avenue, Dept. 125
Bismarck, ND 58505
(701) 328-3644
ctitus@nd.gov

Counsel for Plaintiff State of North Dakota

STEVE MARSHALL
Attorney General
EDMUND G. LACOUR JR.*
Solicitor General

Alabama Attorney General's Office
501 Washington Avenue
Post Office Box 300152
Montgomery, Alabama 36130-0152
Telephone: (334) 242-7300
Facsimile: (334) 353-8400
Edmund.LaCour@AlabamaAG.gov

Counsel for Plaintiff State of Alabama

TIM GRIFFIN
Attorney General
NICHOLAS J. BRONNI*
Solicitor General
DYLAN L. JACOBS*
Deputy Solicitor General

Arkansas Attorney General's Office
323 Center Street, Suite 200
Little Rock, Arkansas 72201
(501) 682-6302
nicholas.bronni@arkansasag.gov

Counsel for Plaintiff State of Arkansas

CHRISTOPHER M. CARR
Attorney General
STEPHEN J. PETRANY*
Solicitor General

Georgia's Attorney General's Office
40 Capitol Square, SW
Atlanta, Georgia 30334
(404) 458-3408
spetrany@law.ga.gov

Counsel for Plaintiff State of Georgia

TREG TAYLOR
Attorney General
CHARLES E. BRASINGTON*
Assistant Attorney General

Alaska Attorney General's Office
1031 West Fourth Avenue, Suite 200
Anchorage, AK 99501
Phone: (907) 269-6612
charles.brasington@alaska.gov

Counsel for Plaintiff State of Alaska

ASHLEY MOODY
Attorney General
NATALIE P. CHRISTMAS* (Fla. Bar 1019180)
Assistant Attorney General of Legal Policy

Florida Attorney General's Office
The Capitol, PI-01
Tallahassee, Florida 32399-1050
(850) 414-3300
(850) 410-2672 (fax)
natalie.christmas@myfloridalegal.com

Counsel for Plaintiff State of Florida

RAÚL R. LABRADOR
Attorney General
DAVID M.S. DEWHIRST*
Chief Deputy Attorney General

Idaho Attorney General's Office
700 W. Jefferson Street, Ste. 210
P.O. Box 83720
Boise, ID 83720-0010
(208) 334-2400
david.dewhirst@ag.idaho.gov

Counsel for Plaintiff State of Idaho

THEODORE E. ROKITA
Attorney General
BETSY M. DENARDI*
Director of Complex Litigation

Indiana Attorney General's Office
Indiana Government Center South
302 W. Washington St., 5th Floor
Indianapolis, IN 46204
(317) 232-6231
Betsy.DeNardi@atg.in.gov

Counsel for Plaintiff State of Indiana

KRIS KOBACH
Attorney General
JESSE A. BURRIS*
Assistant Attorney General

Kansas Attorney General's Office
120 SW 10th Avenue, 2nd Floor
Topeka, Kansas 66612-1597
Tel: (785) 368-8197
Jesse.Burris@ag.ks.gov

Counsel for Plaintiff State of Kansas

ELIZABETH B. MURRILL*
Solicitor General
J. SCOTT ST. JOHN*
Deputy Solicitor General
TRACY SHORT*
Assistant Attorney General

Louisiana Department of Justice
1885 N. Third Street
Baton Rouge, LA 70804
Tel: (225) 326-6766
murrille@ag.louisiana.gov
stjohnj@ag.louisiana.gov
shortt@ag.louisiana.gov

BRENNA BIRD
Attorney General
ERIC H. WESSAN*
Solicitor General

Iowa Attorney General's Office
1305 E. Walnut Street
Des Moines, Iowa 50319
(515) 281-5164
(515) 281-4209 (fax)
eric.wessan@ag.iowa.gov

Counsel for Plaintiff State of Iowa

DANIEL CAMERON
Attorney General
AARON J. SILLETTO*
Assistant Attorney General

Kentucky Attorney General's Office
700 Capital Avenue, Suite 118
Frankfort, Kentucky 40601
Phone: (502) 696-5300
Aaron.Sillette@ky.gov

Counsel for Plaintiff Commonwealth of Kentucky

LYNN FITCH
Attorney General
JUSTIN L. MATHENY*
Deputy Solicitor General

Mississippi Attorney General's Office
550 High Street, Suite 1200
Jackson, MS 39201
Tel: (601) 359-3680
justin.matheny@ago.ms.gov

Counsel for Plaintiff State of Mississippi

Counsel for Plaintiff State of Louisiana

ANDREW BAILEY
Attorney General
JOSHUA M. DIVINE*
Solicitor General
JEFF P. JOHNSON*
Deputy Solicitor General

Missouri Attorney General's Office
Post Office Box 899
Jefferson City, MO 65102
Tel: (573) 751-8870
josh.divine@ago.mo.gov
jeff.johnson@ago.mo.gov

Counsel for Plaintiff State of Missouri

MICHAEL T. HILGERS
Attorney General
ERIC J. HAMILTON*
Deputy Solicitor General

Nebraska Attorney General's Office
2115 State Capitol
Lincoln, NE 68509
(402) 471-2683
Eric.Hamilton@nebraska.gov

Counsel for Plaintiff State of Nebraska

GENTNER F. DRUMMOND
Attorney General
GARRY M. GASKINS, II*
Solicitor General
AUDREY A. WEAVER*
Assistant Solicitor General

Oklahoma Attorney General's Office
State of Oklahoma
313 N.E. 21st Street
Oklahoma City, OK 73105

AUSTIN KNUDSEN
Attorney General
CHRISTIAN B. CORRIGAN*
Solicitor General

Montana Attorney General's Office
215 N Sanders St
Helena, MT 59601
(406) 444-2707
Christian.Corrigan@mt.gov

Counsel for Plaintiff State of Montana

JOHN M. FORMELLA
Attorney General
ANTHONY J. GALDIERI*
Solicitor General
SAMUEL R.V. GARLAND*
Senior Assistant Attorney General

New Hampshire Department of Justice
33 Capitol Street
Concord, NH 03301
(603) 271-3650
samuel.rv.garland@doj.nh.gov

Counsel for Plaintiff State of New Hampshire

ALAN WILSON
Attorney General
J. EMORY SMITH, JR.*
Deputy Solicitor General

South Carolina Attorney General's Office
Post Office Box 11549
Columbia, South Carolina 29211
Phone: (803) 734-3680
Fax: (803) 734-3677
Email: ESmith@scag.gov

(405) 521-3921
Garry.Gaskins@oag.ok.gov
Audrey.Weaver@oag.ok.gov

Counsel for Plaintiff State of Oklahoma

MARTY J. JACKLEY
Attorney General

South Dakota Attorney General's Office
1302 E. Highway 4, Suite 1
Pierre, SD 57501
605-773-3215

Counsel for Plaintiff State of South Dakota

SEAN REYES
Attorney General
MELISSA HOLYOAK*
Solicitor General

Utah Attorney General's Office
350 N. State Street, Suite 230
P.O. Box 142320
Salt Lake City, UT 84114-2320
(801) 538-9600
melissaholyoak@agutah.gov

Counsel for Plaintiff State of Utah

BRIDGET HILL
Attorney General
RYAN SCHELHAAS*

Counsel for Plaintiff State of South Carolina

JONATHAN SKRMETTI
Attorney General and Reporter
ANDRÉE S. BLUMSTEIN*
Solicitor General
CLARK L. HILDABRAND*
Assistant Solicitor General

Tennessee Attorney General's Office
P.O. Box 20207
Nashville, TN 37202
(615) 253-5642
Clark.Hildabrand@ag.tn.gov

Counsel for Plaintiff State of Tennessee

JASON MIYARARES
Attorney General
ANDREW N. FERGUSON*
Solicitor General
KEVIN M. GALLAGHER*
Deputy Solicitor General
M. JORDAN MINOT*
Assistant Solicitor General

Virginia Attorney General's Office
202 North 9th Street
Richmond, Virginia 23219
(804) 786-2071
aferguson@oag.state.va.us
kgallagher@oag.state.va.us

Counsel for Plaintiff State of Virginia

Chief Deputy Attorney General

Wyoming Attorney General's Office
Counsel for the State of Wyoming
109 State Capitol
Cheyenne, WY 82002
Telephone: (307) 777-5786
ryan.schelhaas@wyo.gov

Counsel for Plaintiff State of Wyoming

**pro hac vice or admission application forthcoming*